

RECOMMENDED FPC/FFC DIMENSIONS

RECOMMENDED PCB LAYOUT

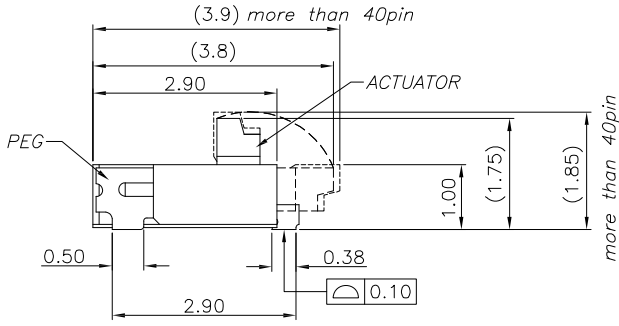
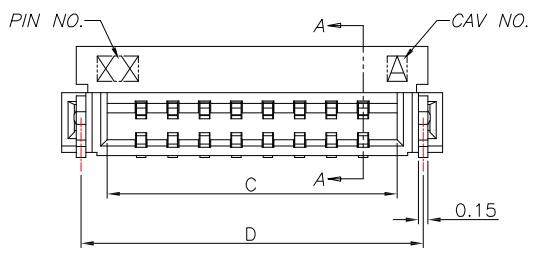

SPECIFICATIONS

Electrical Characteristics:

- 1.1 Current rating: 0.5A
- 1.2 Voltage rating: 50V AC
- 1.3 Operating Temperature range: -55°C ~ +85°C
- 1.4 Operating Humidity range: Relative Humidity 90% Max
- 1.5 Storage Temperature range: -10°C ~ +50°C
- 1.6 Storage Humidity range: Relative Humidity 90% Max

Material:

- 1.1 Housing: LCP
- 1.2 Contact: Phosphor Bronze, Gold Plated
- 1.3 Peg : Phosphor Bronze, Nickel Plated
- 1.4 Actuator: HTN

Number of Contacts	DIM A	DIM B	DIM C	DIM D	DIM E	DIM F	DIM G
50	27.00	24.50	25.57	26.39	26.10	26.90	25.50
45	24.50	22.00	23.07	23.89	23.60	24.40	23.00
42	23.00	20.50	21.57	22.39	22.10	22.90	21.50
40	22.00	19.50	20.57	21.39	21.10	21.90	20.50
36	20.00	17.50	18.57	19.39	19.10	19.90	18.50
34	19.00	16.50	17.57	18.39	18.10	18.90	17.50
32	18.00	15.50	16.57	17.39	17.10	17.90	16.50
30	17.00	14.50	15.57	16.39	16.10	16.90	15.50
28	16.00	13.50	14.57	15.39	15.10	15.90	14.50
26	15.00	12.50	13.57	14.39	14.10	14.90	13.50
24	14.00	11.50	12.57	13.39	13.10	13.90	12.50
23	13.50	11.00	12.07	12.89	12.60	13.40	12.00
22	13.00	10.50	11.57	12.39	12.10	12.90	11.50
20	12.00	9.50	10.57	11.39	11.10	11.90	10.50
18	11.00	8.50	9.57	10.39	10.10	10.90	9.50
17	10.50	8.00	9.07	9.89	9.60	10.40	9.00
16	10.00	7.50	8.57	9.39	9.10	9.90	8.50
15	9.50	7.00	8.07	8.89	8.60	9.40	8.00
14	9.00	6.50	7.57	8.39	8.10	8.90	7.50
13	8.50	6.00	7.07	7.89	7.60	8.40	7.00
12	8.00	5.50	6.57	7.39	7.10	7.90	6.50
11	7.50	5.00	6.07	6.89	6.60	7.40	6.00
10	7.00	4.50	5.57	6.39	6.10	6.90	5.50
09	6.50	4.00	5.07	5.89	5.60	6.40	5.00
8	6.00	3.50	4.57	5.39	5.10	5.90	4.50
7	5.50	3.00	4.07	4.89	4.60	5.40	4.00
6	5.00	2.50	3.57	4.39	4.10	4.90	3.50
5	4.50	2.00	3.07	3.89	3.60	4.40	3.00
4	4.00	1.50	2.57	3.39	3.10	3.90	2.50



TOLERANCE UNLESS OTHERWISE STATED :
 Up to 5 ±0.2
 Above 5 ~ 15 ±0.3
 Above 15 ~ 30 ±0.4
 Above 30 ~ 50 ±0.5
 Angle ±0.3

3RD. ANGEL'S



UNITS

MM

DRAWN BY: Jack Lu
 CHECKED BY: Jacky Chen
 APPROVED BY: Tony Kao

DATE: 08/09/23
 DATE: 08/09/23
 DATE: 08/09/23

MAT'L		TITLE	CONNECTOR
FINISH		MODLE	0.5mm H:1.0 FPC 後掀式 Cable T:0.2mm
SCALE	1 : 1	DWG NO.	FPC05L-10xx-C2-S149
SHEET NO.	1 of 1	PART NO.	FPC05L-10xx-C2-S149
		SIZE	A4
		VER	R1

ITEM NO.	DESCRIPTION	DRAWN	DATE
1	更新圖面	Jack	080923